

M-218-08

Troubleshooting Guide Chipspreaders

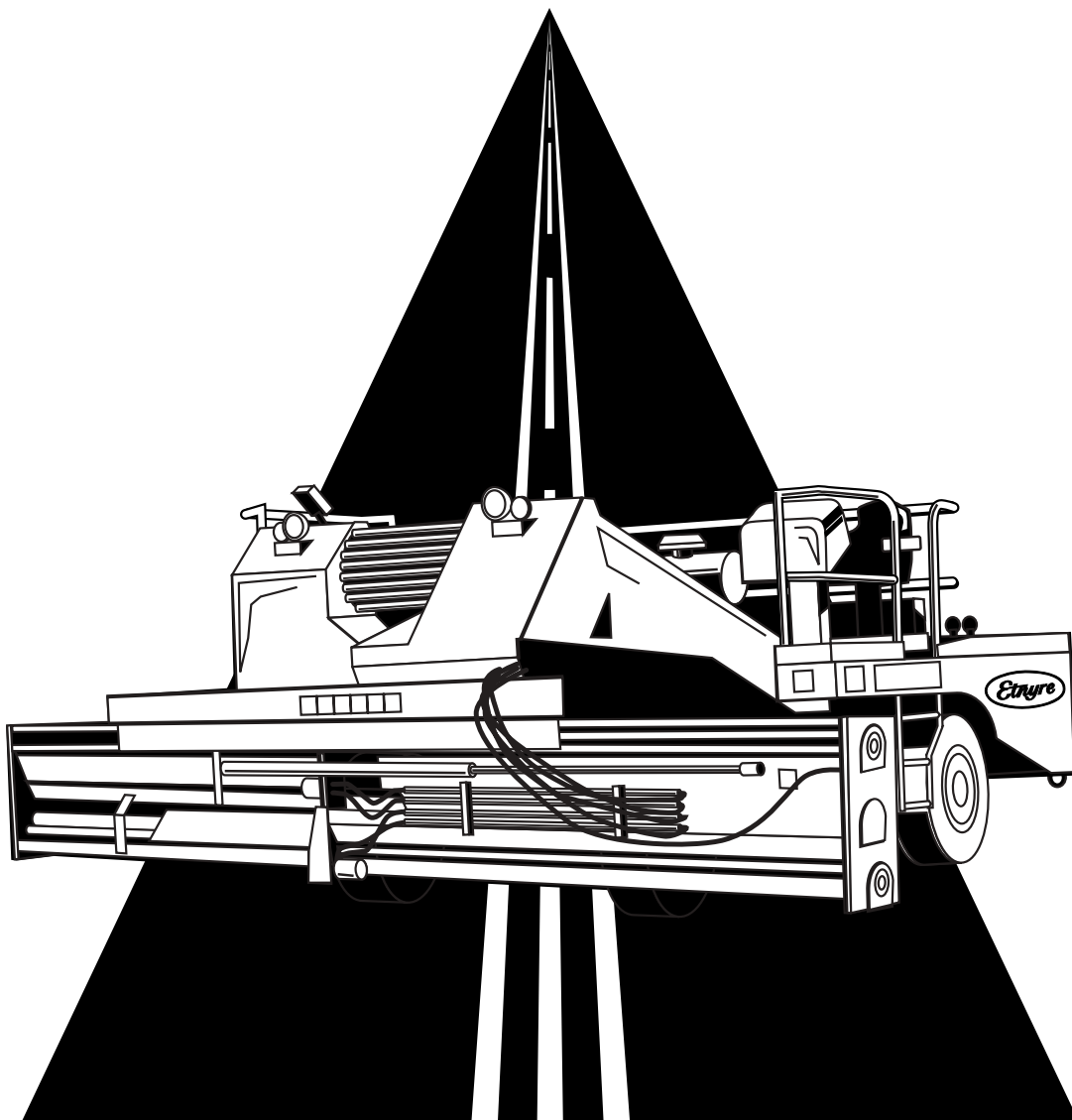

E. D. ETNYRE & CO.

Troubleshooting Guide

Chipsreaders

Contents

Speed sensor error (failure)	2
Fuel sender alarm.....	4
Low oil pressure alarm	5
Water temperature alarm.....	7
Hydraulic oil temperature alarm	9
Gate sensor failure alarm (Rexroth Computer)	10
Checking solid state gate transducer	13
Gates open / close faster than other side.....	14
Air gates out of adjustment (very loud noise as master power is turned on / off).....	16
Spreadroll speed fluctuating.	18
Hydraulic Stand-by (load sense) pressure is fluctuating (needle not steady on gauge).....	20
Overlap or streak in center when hoppers are fully extended. ...	22
No gradability	23
Auxiliary hydraulic pressure will not relieve	24
Computer Wiring Connections	26



E.D ETNYRE & CO.
1333 S. Daysville Road, Oregon, IL 61061
Phone: 1-800-995-2116
Fax: 815-732-7400
Web Site: www.etnyre.com

Problem # 1

Speed sensor error (failure)

Check to make sure joystick is in neutral (alarm will sound if joystick is out of neutral and machine does not move).

- 1) Check fuses or circuit breakers
- 2) Check speed sensor
 - a) Check for loose sensor
 - b) Poor alignment (see figure # 1A & 1B)
 - c) Improper clearance- 1/16" recommended
 - d) Loose wiring connection
 - e) Pinched or rubbed wiring
- 3) Check wiring from computer to speed sensor (with harness disconnected).
 - a) Red wire (12 VDC)
 - b) Black wire (ground)
 - c) Clear or white wire (signal 9-10 VDC)
 - d) Shield (ground)If voltages and grounds are (OK), proceed with step # 4
If voltages and grounds are (NOT OK), proceed with step # 5
- 4) Check power at speed sensor (with harness connected)
 - a) Red wire (12 VDC)
 - b) Black wire (ground)
 - c) Clear or white wire (signal 4-7 VAC while machine is moving) No signal, replace speed sensor
 - d) Shield (ground)
- 5) Check connections at computer (with speed sensor disconnected)

COMPUTER CONNECTION IDENTIFICATION ON PAGE # 24

- a) P1-PIN 21 (speed sensor power 12 VDC)

If voltage is (OK) but no voltage was present in step # (3a) check wiring between computer and speed sensor for continuity. If no continuity is present, replace harness asm.

No voltage - bad connection or bad computer output.

- b) Ground (attached to computer base)

Problem # 1 continued

c) P3-PIN 10 (9-10 VDC)

If voltage is (OK) but no voltage was present in step (3c) check wiring between computer and speed sensor for continuity. If no continuity is present, replace wiring harness asm.

If NO voltage is present, check voltage on other end of pull-up resistor attached to (P3-PIN10). Should be (12 VDC). If you have (12 VDC), replace resistor (1k OHM)

d) Ground (attached to computer base)

SPICER AXLES

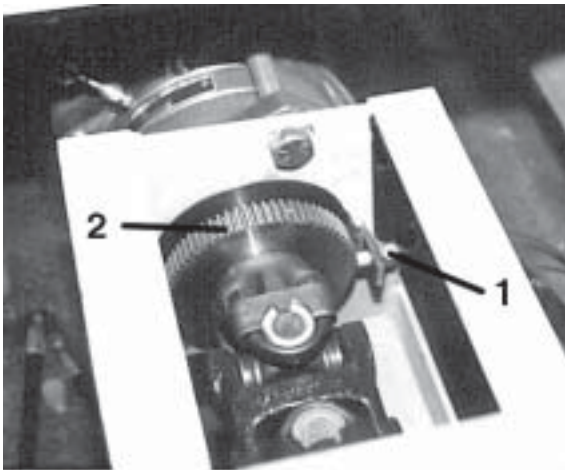

Figure 1A

- 1) Mag pick-up
- 2) Pick-up gear

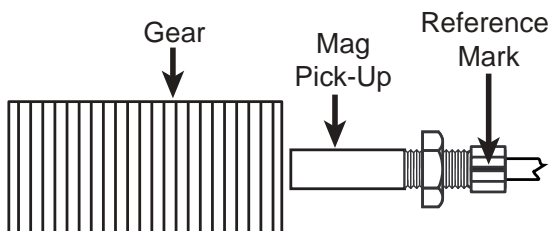

Figure 1B

KESSLER AXLES

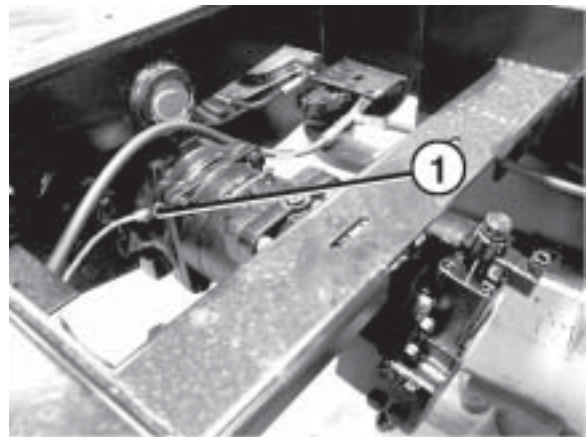

Figure 1C

- 1) Mag pick-up

Speed Sensor for Kessler Axles

Part No. 6703670

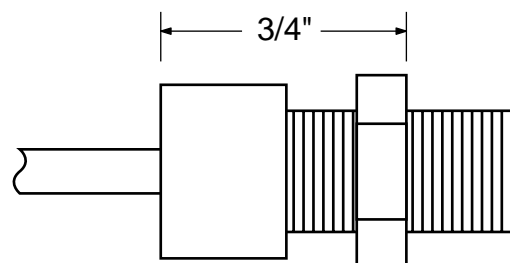

Figure 1D

Problem # 2

Fuel sender alarm

- 1) Check fuel level. If not low on fuel proceed with step #2.
- 2) Check for debris lying on top of sending unit (metallic).
- 3) Check wiring connection for loose or bad connection (frayed wire touching ground).
- 4) Disconnect wire from sending unit.

If alarm quits: (see figure #2 for resistance values)

If alarm persists: proceed to step #5.

- 5) Check wiring between sender and computer.
- 6) Check connection at computer (loose connector).
- 7) Check connection at computer terminal (P2-PIN19)

COMPUTER CONNECTION IDENTIFICATION ON PAGE # 24

Arm Angle (degrees)	Ohms	Display Reading (%)	Gallons Remaining (total)	Gallons Remaining (useable)
50.00	250	100	68	65
45.20	240	100	65	62
39.58	227	95	57	54
34.38	216	90	54	51
29.49	206	85	52	49
24.82	196	80	50	47
20.32	186	75	46	43
15.95	176	70	43	40
11.68	167	65	41	38
7.47	158	60	38	35
3.30	149	55	35	32
-0.86	140	50	32	29
-5.01	131	45	30	27
-9.20	122	40	27	24
-13.43	113	35	24	21
-17.74	104	30	21	18
-22.16	94	25	18	15
-26.72	84	20	16	13
-31.47	74	15	13	10
-36.48	63	10	10	7
-41.83	52	5	7	4
-47.70	39	0	5	2
-50.00	34	0	4	1

Figure 2

Problem # 3

Low oil pressure alarm

- 1) Install a mechanical gauge and verify engine oil pressure (approx 30 psi @ idle, 65 psi @ full rpm, with engine coolant at operating temperature 160° - 190°F)
- 2) Check wiring at sensor for bad or loose connection.
- 3) Ground sensor wire to engine block to see if alarm quits.
If alarm quits, see calibration chart below for resistance values.
If alarm persists, proceed to step #4.
- 4) Check computer connector P2 and P3.

COMPUTER CONNECTION IDENTIFICATION ON PAGE # 24

- 5) Check connections at computer
 - Oil pressure sender (P2-PIN18)
 - Oil pressure ground (P2-PIN2)
- 6) Look for wires pulled out, touching or possibly disconnected.
- 7) Check continuity of wiring between computer and oil pressure sender.
- 8) Install new oil pressure sender unit with OEM replacement. (Resistance values have to be correct for oil pressure to work properly)

Important Information:

Alarm activated: 5 psi @ 1400 R.P.M.and below
 10 psi @ 1401 R.P.M.and above

(Above readings must exist for (2) two seconds for alarm to activate).

See figure # 3 on page # 6 for proper resistance values.

Display Reading (P.S.I.)	Ohms (min)	Ohms (nominal)	Ohms (max)
0	225	240	257
5	210	223	240
10	196	217	224
15	183	192	209
20	171	179	194
25	160	167	180
30	150	156	168
35	142	146	156
40	134	137	146
45	126	128	136
50	120	121	127
55	113	113	117
60	106	106	106
65	100	100	100
70	93	93	93
75	87	87	87
80	82	82	82
85	76	76	76
90	72	72	72
95	66	66	66
100	60	60	60
105	54	54	54
110	50	50	50
115	44	44	44
120	38	38	38
125	33	33	33

Figure 3

Problem # 4

Water temperature alarm

- 1) Check and verify coolant is exceeding 240°F using laser probe or mechanical temperature gauge.
 - If coolant is not hot, proceed with step #2
 - If coolant is exceeding 240°F, proceed to step #7
- 2) Check wiring terminal at sensor (loose or bad connection).
- 3) Check wiring.
 - a) frayed wiring
 - b) bare wiring
- 4) Disconnect sensor and check to see if alarm quits
 - If alarm quits (See figure # 4 page #8 for resistance values).
 - If alarm persists continue with step #5.
- 5) Check for loose or bad connection at computer (P2)
- 6) Check wiring from sensor to computer
 - computer connection (P2-PIN20)

COMPUTER CONNECTION IDENTIFICATION ON PAGE # 24

- 7) Check engine coolant level (using caution while taking off radiator cap.)
- 8) Check and clean out any debris in front of radiator.
- 9) Check to see if radiator and/or hydraulic cooler is plugged up with aggregate dust and/or particles. (Clean if this condition exists)
- 10) Check for any leaks in cooling system. (Leaks will allow particles to collect).
- 11) If overheating condition persists, investigate further into radiator and/or engine problem.

Ohm Range (min)	Ohm Range (max)	Display Reading (temperature °F)
	325	100
296	324	105
266	295	110
236	265	115
211	235	120
185	210	125
168	184	130
152	167	135
138	151	140
125	137	145
111	124	150
101	110	155
94	100	160
86	93	165
81	85	170
74	80	175
68	73	180
64	67	185
58	63	190
55	56	195
52	54	200
47	53	205
44	46	210
41	43	215
37	40	220
34	36	225
29	33	230
28	28	235
26	27	240

Figure 4

Problem # 5

Hydraulic oil temperature alarm

- 1) Check oil level.
- 2) Verify that temperature of hydraulic oil is over 180° F, using laser probe or mechanical temperature gauge.
 - If temperature is above 180°F, continue with Step #3.
 - If temperature is below 180°F, skip to Step #9.
- 3) Check for filter restriction (gauges located on filter bases). If gauge is damaged or broken it should be replaced.
- 4) Check for debris trapped in front of hydraulic cooler. (Debris indicates possible leak in hydraulic or cooling system).
- 5) Check for debris trapped between the hydraulic cooler and engine radiator. (Debris indicates possible leak in hydraulic or cooling system).
- 6) Try to identify source of heat generation, (relief-manifold-block-quick coupling-hydraulic fitting-hose).
- 7) Check to see if hydraulic system is plumbed properly (especially thru the hydraulic cooler).
- 8) ..Check hydraulic pressures to ensure that they are not above the allowable limits. (Ref: Problem #14)
- 9) . Check connection at temperature sensor (on hydraulic reservoir tank) for a loose or bad connection.
- 10) Disconnect sensor wire to see if alarm quits.
 - If alarm quits see chart below for resistance values.
 - If alarm persists continue with Step #11.
- 11) Check connection at computer (Plug –P2).

COMPUTER CONNECTION IDENTIFICATION ON PAGE # 24

- 12) Check wiring from sensor to computer (P2-PIN17)
- 13) Check wiring for short to ground

See figure # 4 page # 8 for proper resistance values.

Problem # 6

Gate sensor failure alarm (Rexroth Computer)

- 1) Check gate transducer on side indicated by digital display.
- 2) Check for plug disconnected at sensor.
 - a) Broken or pinched wiring
 - b) Bad, corroded or loose connection
- 3) Check transducer (fixed or variable hopper) potentiometer type see # 4.

For units with solid state transducer (wiring color code red-blue-black)

- a) Make sure that gate is fully closed.
- b) Do not unplug sensor from harness (this sensor is checked by voltage related to sensor position).

Adapter (Etnyre part # 7050350) is available so that tapping into and stripping wires is not needed.

- c) Check voltage on red wire terminal (voltage supplied to transducer) ground using black wire terminal. Reading should be (5.0 VDC).
- d) Check voltage on the blue wire terminal (transducer signal voltage) ground using black wire terminal. Reading should be between (0.5 – 1.5 VDC). Ideal setting (1.0 VDC).
- e) Make adjustment by rotating transducer if not within these parameters.

See figure # 5 for proper adjustment procedure.

- f) Re-calibrate (null/scale) gate calibrations in computer set-up if adjustment was made.

Material will need to be re-calibrated if transducer is adjusted.

For units with resistor type potentiometer (wiring color code orange-green-black)

- 4) Adjusting potentiometer (old type)
 - a) Make sure that gate is fully closed.
 - b) Unplug sensor from harness
 - c) Check OHMS across the orange and green wire terminals at the connector attached to the potentiometer.

Problem # 6 continued

- d) Reading should be between (250 – 270 OHMS).
- e) Make adjustment if not within these perimeters.
- f) Re-calibrate (null/scale) gate calibrations in computer set-up if adjustment was made.

NOTE: OHMS increase as gate opens, so it is critical not to exceed (270 OHMS) on this potentiometer.

- g) If failure is still present after transducer or potentiometer adjustment is made, proceed with # 5.
- 5) Check wiring for continuity between transducer or potentiometer and computer.
 - 6) Check connections at computer (Rexroth)

COMPUTER CONNECTION IDENTIFICATION ON PAGE # 24

Fixed hopper or Left gate + (P1-PIN10) Red
Left gate – (P1-PIN18) Black
Left gate wiper (P1-PIN6) Clear
Right gate + (P1-PIN11)Red
Right gate – (P1-PIN19)Black
Right gate wiper (P1-PIN7)Clear

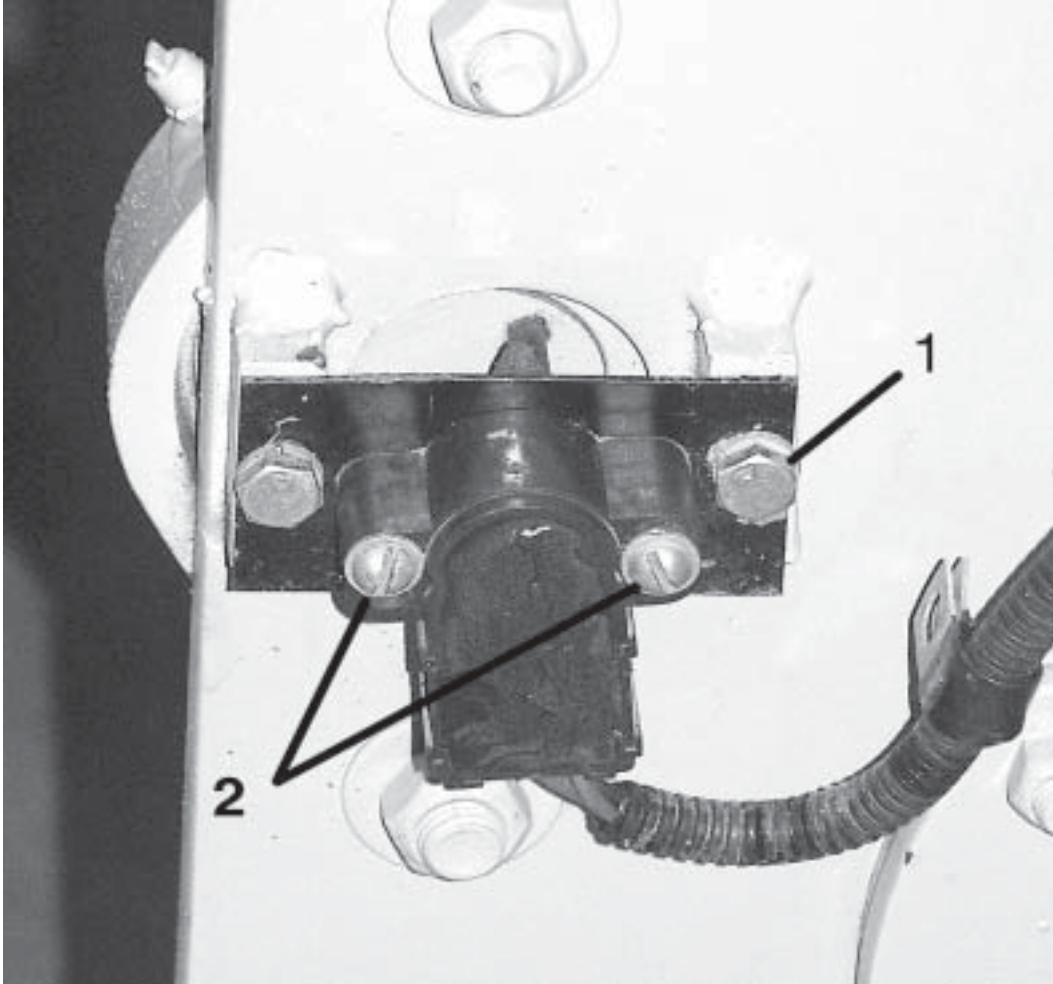

Figure 5

- 1) Mounting bolts*
- 2) Sensor adjustment screws (loosen and rotate sensor)*

Problem # 7

Checking solid state gate transducer

REXROTH COMPUTERS (FIXED AND VARIABLE HOPPER)

Wiring Color Code:

A) **RED – RED**

B).....**BLUE – WHITE**

C).....**BLACK – BLACK**

Adjustment Procedure:

- 1) Verify and make sure that gate is fully closed.
- 2) Test with wiring and sensors still connected (adapter available from Etnyre Part # 7050350).
- 3) Check voltage on the red wire-transducer input voltage (5 VDC) not adjustable. Ground using black wire terminal.
- 4) Check voltage on the blue wire-transducer signal (0..5-1.5 VDC) ideal setting is (1.0 VDC) ground using black wire terminal.
- 5) Re-calibrate (null/scale) gate calibrations in computer set-up if adjustment made

(See figure # 5 for proper adjustment procedure).

material will need to be re-calibrated if transducer is adjusted

- 7) Move transducer to simulate the gate opening, watch the transducer signal voltage as you actuate the transducer, the voltage should increase as the gate opens by 3 VDC over a 4-inch gate opening. Ensure that the signal is smooth and there is no interruption in the sweep of the transducer.

(Transducer signal output voltage examples).

Transducer range detached from unit (0-5 VDC)

Transducer range attached to gate assembly (3 VDC)

(Example: If signal voltage is 1 VDC with gate fully closed, voltage with gate fully open should not exceed 4 VDC.)

Problem # 8

Gates open / close faster than other side

- 1) Enter computer set-up. Hold down the calibrate switch and turn ignition switch to ACC or on position, release switch after alarm sounds (3) three times.
 - a) . Scroll thru using the scroll switch until “right gate open” appears. This is the amount of power (amps) that it takes to energize and operate the gate. The higher the amps, the faster the gate operates. This number should not exceed 1.2 amps or it can create gate fluctuation.
 - b) Scroll to next screen “right gate closed” adjust if needed (1.2 amps max.).
 - c) Scroll to next screen “left gate open” adjust if needed (1.2 amps max.).
 - d) ... Scroll to next screen “left gate closed” adjust if needed (1.2 amp max.).

On machines that have (1) one fixed hopper, the left gate open/close controls the gate speed.

On Variable width machines that have (2) two hoppers that both spread backwards these speeds can be the same. The gate hold, gate shut hold and the spread roll timer are the components that are instrumental in the control of the material stagger (straight line start/stop). Gate fluctuation could occur on these units if the open/close amps are not the same or similar.

On Variable width machines that have (1) one hopper that spreads backward and (1) one hopper that spreads forward, these numbers are instrumental in the timing of the material stagger (straight line start/stop).

If adjusting the gate speeds and the amps does not correct the problem, proceed with # 2

- 2) Check and verify hydraulic pressure on gate relief valve(s).
- 3) Check wiring connections at gate valve.
- 4) Check connection at the Harting (HON) connector mounted on the left outside conveyor rail. Variable width units the harting (HON) connector for the right side is mounted under the right conveyor above the right front tire.

Problem # 8 continued

5) Check output to gate valve.(amp output should match the output threshold set in the computer for gate open / close).

Gate valve connector - terminal (1) Red wire – power to valve
terminal (2) Black wire – ground

6) Check computer connections

COMPUTER CONNECTION IDENTIFICATION ON PAGE # 24

(P4-PIN 5) Right gate open solenoid (+)

Ground post (-)

(P4-PIN 6) Right gate close solenoid (+)

Ground post (-)

(P4-PIN 3) Left gate open solenoid (+)

Ground post (-)

(P4-PIN 4)Left gate close solenoid (+)

Ground post (-)

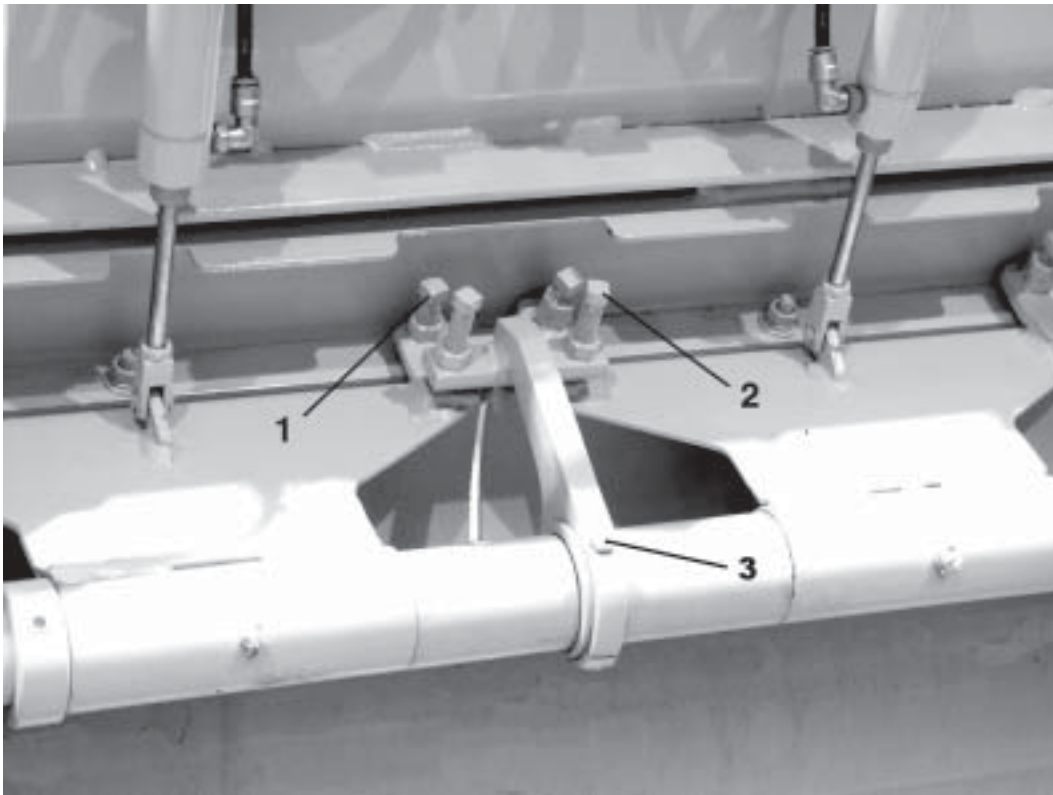

Figure 6

- 1) Air gate adjustment screw*
- 2) Hydraulic gate buss arm adjustment screw*
- 3) Buss arm asm bolt*

Problem # 10

Spreadroll speed fluctuating.

- 1) Check auxiliary stand-by pressure. If the stand-by pressure is too low the pump will not come on stroke quick enough, causing not enough pressure and flow will be supplied to the spread roll.

Check applicable chart for proper stand-by pressure. Procedures for adjusting stand- by pressure available in operation manual for machine.

- 2) Check and adjust speed of spread roll (RPM) at flow control cartridge.

On standard hopper units this cartridge is located in the gate/spread roll manifold (check applicable chart for proper RPM.) located in operation manual for machine.

On variable width hopper units this cartridge is located in the auger/spread roll manifolds. Left and right spreadrolls have separate cartridges. Check applicable chart located in the operation manual for the machine,for proper spreadroll RPM.

If the adjustment of spread roll RPM made in step 1 & 2 does not correct the problem, proceed with step # 3

- 3) Remove and inspect spread roll flow control cartridge for contamination or debris.

If no contamination is found or problem is not corrected, proceed with step #4.

- 4) Monitor auxiliary stand by pressure. Procedure for checking stand-by pressure is located in the operations manual for machine. Watch to see if spread roll speed follows the pressure (Example: as the pressure decreases the spread roll speed decreases etc.)

If this problem exists proceed to step #5.

- 5) Remove load sense checks (2) and inspect for contamination or debris (worn spring or pitted seat assembly).

Load sense check location:

On standard hopper units, the load sense checks (2) are located on the top of the conveyor manifold. (See figure # 7)

On variable width hopper units, the load sense checks (2) are located on the top of the auger/spread roll manifolds.(See figure # 8)

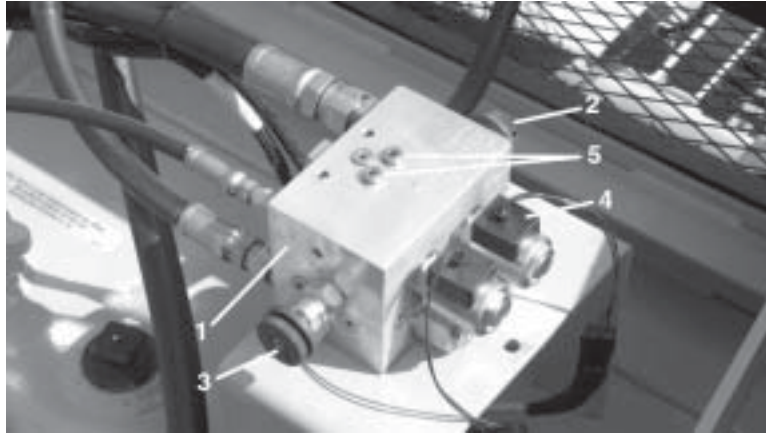

Figure 7

- | | |
|----------------------------|----------------------------|
| 1) Conveyor manifold block | 4) 12 VDC Coil |
| 2) Rt Conv Speed Control | 5) Load Sense Check Valves |
| 3) Lt Conv Speed Control | |

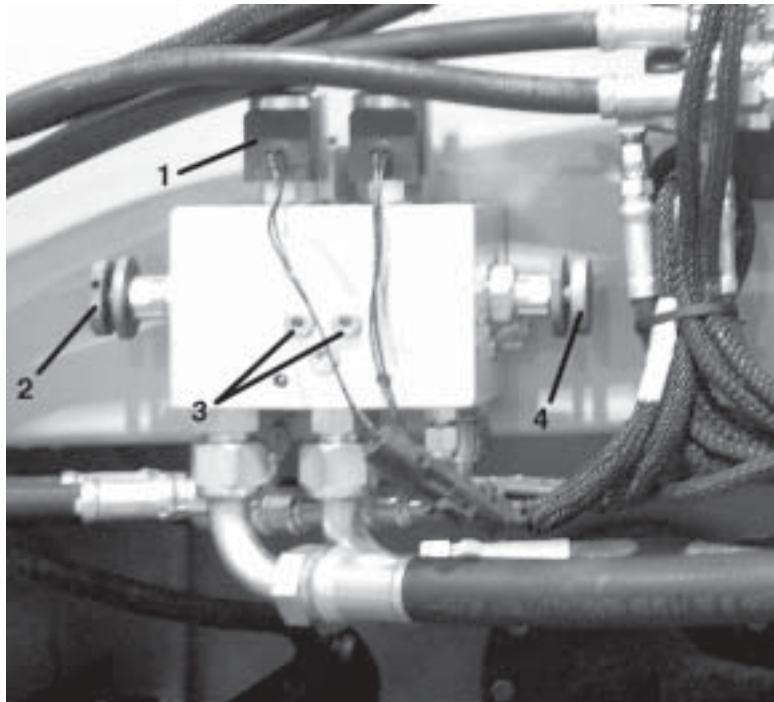

Figure 8

- | | |
|--------------------------------|----------------------------|
| 1) 12 VDC Coil | 3) Load Sense Check Valves |
| 2) Lt Spreadroll Speed Control | 4) Lt Auger Speed Control |

Problem # 11

Hydraulic Stand-by (load sense) pressure is fluctuating (needle not steady on gauge)

- * This happens when the volume of oil present in the load sense system is too great, due to a missing or contaminated orifice or load sense check valve.

- 1) Check the orifice in load sense line fitting(s) attached to auxiliary hydraulic pump(s) load sense compensator valve.(see figure 9 item 3).
 - a) Check to insure that the orifice is installed in fitting (set screw installed inside fitting with .040 hole drilled in it).
 - b) Check the orifice for contamination
 - c) Verify the orifice size (.040)

- 2) Check the compensator operation to ensure that pressure is responding to demand of hydraulic system. Procedure for checking stand-by pressure is in the operation manual for machine.

- * Bad or contaminated load sense check valves can cause erratic stand-by pressures. (see figure 7 & 8 to identify location of load check valves).
 - a) Check and/or set the stand-by pressure. With the engine shut off, remove the load sense lines from the compensators and cap them off. (see figure 9 item 4,5,6& 7) for the location of the lines. Check and set stand-by pressure using correct procedure in operation manual for machine. If proper stand-by pressure is obtained and remains steady with no fluctuating, proceed with step (b). If proper stand-by pressure is not achieved, possible pump and/or compensator problem.
 - b) Attach the load sense lines one at a time to determine which hydraulic manifold block has a contaminated or bad load sense check valve.
 - c) Check load sense check valve(s) for contamination, replace if needed.

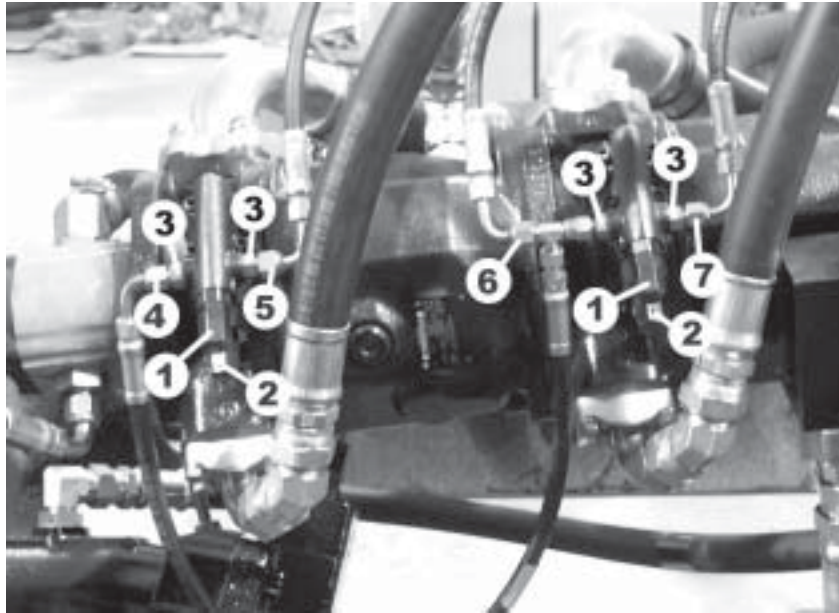
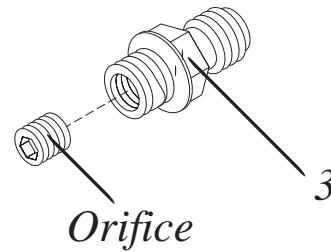

Figure 9



- 1) Load Sense Adjustment
- 2) Main Pressure Adjustment
- 3) Load Sense Fitting w/ Orifice
- 4) Load Sense Jumper Hose between compensators
- 5) Hose to load sense port on Lt hopper manifold block
- 6) Hose to load sense port on conveyor manifold block
- 7) Hose to load sense port on Rt hopper manifold block

Verify routing of hoses (5,6&7) to insure correct hydraulic manifold is identified.

- * Standard hopper units will only have (1) auxiliary pump and (1) load sense line going to the conveyor manifold block. (load sense line between the conveyor block and the gate / spreadroll manifold block, will have to be removed and capped to isolate conveyor block. Each block has a "LS" stamped on the block to identify port)

Problem # 12

Overlap or streak in center when hoppers are fully extended.

This problem is adjustable as follows:

If the material is heavy in the middle and a overlap is present, the gate cut-off plate needs to be adjusted by sliding it in the hopper further (adjust both sides evenly). See figure # 10.

If the material is leaving a void or streak down the center of the road, first adjust cut-off plate by sliding it out of the hopper further. See figure # 10. If the cut-off plate cannot be adjusted any further, adjust the hopper (in/out) cylinder at the rod end of the cylinder. (adjust both sides evenly). See figure # 11.

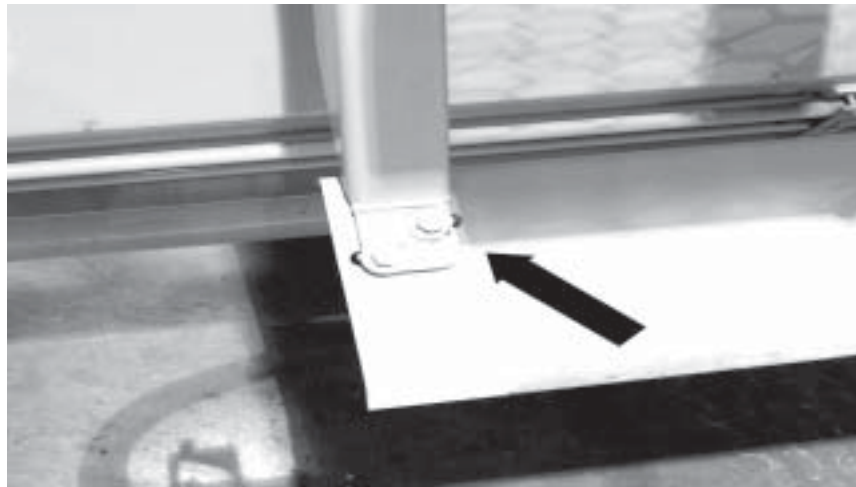

Figure # 10

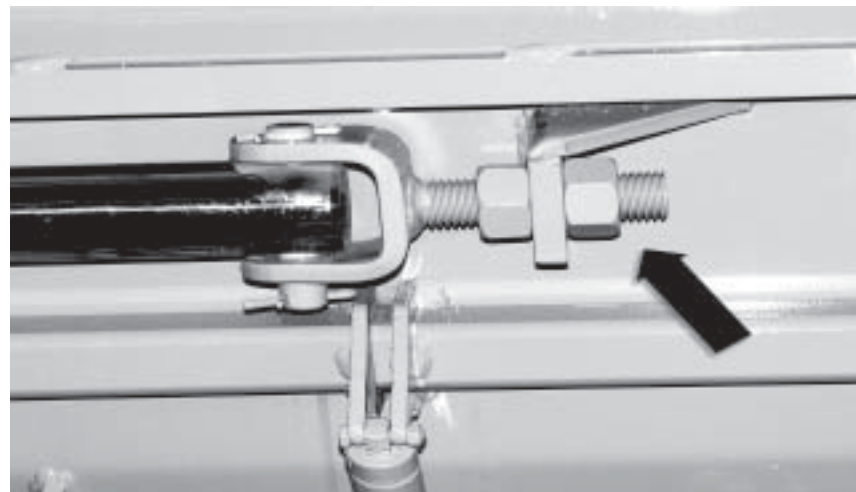

Figure # 11

Problem # 13

No gradability

- 1) Verify grade of incline. (Is grade too steep for machine to climb).
All % calculations with combined weigh of (chipsreader / dump truck / aggregate) 80,000 Ibs. Max.

Engine R.P.M. @ 2200 Computer speed set-point F.P.M. @ 200

2Wheel Drive – 6-8%

4Wheel Drive with 107cc motors 8-12%

4Wheel Drive with 160cc motors 12-18%

Motor size (cc) stamped on tag, attached to top of drive motor.

If % of grade is acceptable proceed with # 2

- 2) 2Wheel Drive Machines
 - a) Disconnect the electrical connector attached to the front drive hydraulic motor servo (secure wire).
 - b) Test unit on grade with 80,000 Ibs.
- 3) 4Wheel Drive Machines
 - a) Disconnect the electrical connector attached to both front and rear drive hydraulic motor servos. (secure wires)
 - b) Test unit on grade with 80,000 Ibs.

If disconnecting servo connectors allows machine to pull the grade, reconnect servos one at a time, and test unit to identify which motor servo is causing problem. (servo is receiving power that is changing the position of the internal swash plate of the hydraulic motor).

If disconnecting hydraulic motor servo connectors does not correct or improve performance proceed with # 4.

Procedures for checking hydraulic pressures can be found in operation manual for machine.

- 4) Check and verify hydrostat priority override (POR) hydraulic pressure.
- 5) Check and verify hydrostat main hydraulic pressure (FWD).
- 6) Check and verify hydrostat main hydraulic pressure (REV).

Problem # 14

Auxiliary hydraulic pressure will not relieve

Other Problems affected:

#5 Hydraulic oil temperature alarm

Problem is found during the process of checking pressures of the auxiliary hydraulic pumps #2 & 3. Pump #2 is fixed head unit.

The main pressure must relieve after checking main pressure or auxiliary pump will not de-stroke which creates heat and torque loss of engine and hard start condition if shut off between use.

To correct the problem:

- Shut off machine.
- Close and shut off main hydraulic suction valve.
- Locate and cap off case drain at pump.
- Remove compensator from hydraulic pump(s).
- Remove load sense compensator cartridge.
- Locate allen head 2mm (orifice) inside housing (see Figure 12)

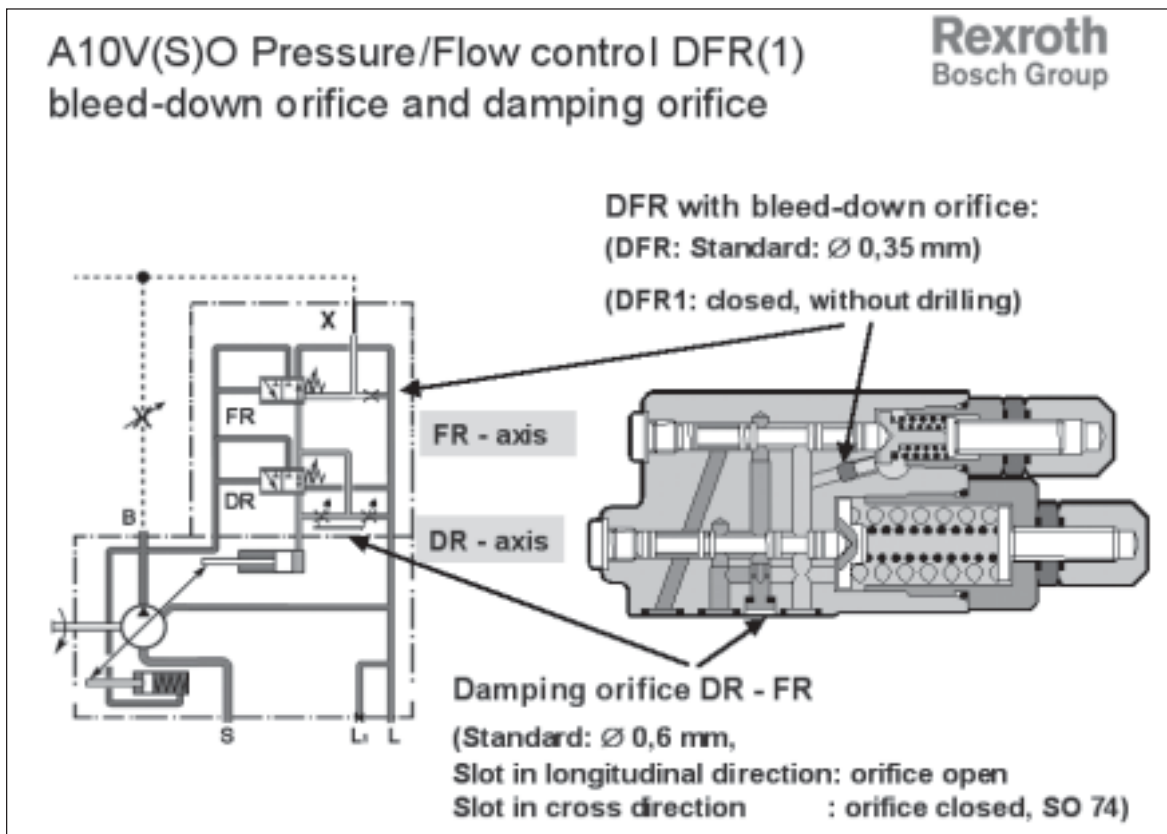

Figure 12

- Remove orifice.
- Clean out orifice with strand of primary wire or torch cleaning kit (if small enough).
- Re-install orifice.
- Re-install cartridge.
- Re-install compensator.
- Uncap and reinstall case drain hose.
- Open suction valve.
- Install air regulator to hydraulic tank through vent filter connection.
- Apply 3 - 5 lbs to hydraulic system to push any trapped air in hydraulic system out.

Start machine and operate all functions to ensure hydraulic oil circulation.

Check and adjust pressures. Procedure located in operation manual for machine. *Be sure to have correct manual.*

Check to see if pressure relieves after main pressure is achieved.

If unable to adjust pressures on pump - pump may have sustained damage due to previous condition (won't stroke).

Isolation of pumps will be necessary to find out which pump is affected.

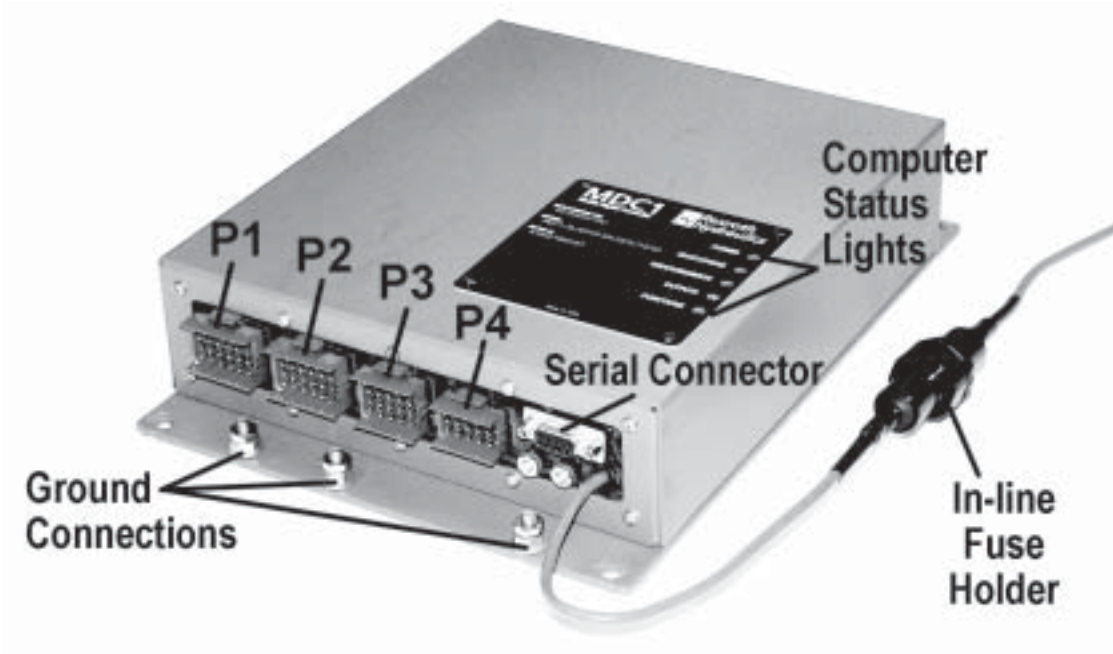

Computer Wiring Connections

